



# Antennas

DATA SHEET

## Wideband Bi-Sector™ Antenna

BSA33R-W3A

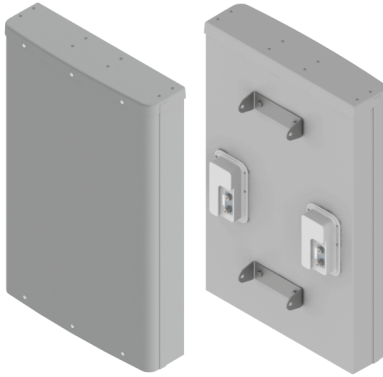

- Three foot (0.9 m), Wideband, eight port Bi-Sector™ Antenna. Deploying a high performing two pairs of CCI's Patented Asymmetrical 33° Shaped Beams covering 1695-2180 MHz frequencies
- Eight wide High Band ports (4 ports per beam) covering 1695-2180 MHz and in a single antenna
- Full Spectrum Compliance for 1695-2180 MHz Operations
- LTE Optimized Asymmetric Shaped Beams for improved LTE data throughput by minimizing beam crossover, providing for an efficient use of valuable radio capacity and frequency spectrum
- LTE Optimized FBR, SPR and Boresight/Sector XPD Performance, essential for today's LTE Data Networks
- Exceeds minimum PIM performance requirements
- Equipped with new 4.3-10 connector, which is 40% smaller than traditional 7/16 DIN connector
- Equipped with Two Field Replaceable, integrated AISG 2.0 compliant Remote Electrical Tilt (RET)

### Overview

This version of the CCI Bi-Sector™ Wideband Array is an eight port antenna, with eight wide High Band ports (four per beam) covering 1695-2180 MHz. The CCI Bi-Sector™ array uses a two pairs of CCI's High Performing Patented Asymmetric 33° Shaped Beams in the High Band frequencies. The CCI Bi-Sector™ Array thus provides the capability to deploy Dual (over split beams) 4x4 Multiple-input Multiple-output (MIMO) in the High Band. The CCI Bi-Sector™ Array utilizes two RET controllers, with a separate RET controller for each of CCI's Patented Asymmetric 33° Shaped Beams.

The CCI Bi-Sector™ Wideband Array, allow operators to reduce antenna count and replace existing 65° networks, while increasing cell site capacity and LTE data throughput by minimizing overlap between CCI's Patented Asymmetric 33° Shaped Beams. This design approach lowers interference between sectors. All of this is achieved through a single panel array, producing significant CAPEX and OPEX cost savings for the operator.

CCI antennas are designed and produced to ISO 9001 certification standards for reliability and quality in our state-of-the-art manufacturing facilities.

### Applications

- With CCI's Bi-Sector™ Wideband Antenna, wireless operators can connect multiple platforms to a single antenna, reducing tower load, lease expense, deployment time and installation cost
- Ideal Antenna Solution for structurally constrained sites, where data throughput, capacity and limited spectrum is a concern
- Quad (over split beams) 4x4 MIMO in High Band
- Ready for Network Standardization on 4.3-10 connectors



# Antennas

## SPECIFICATIONS

### Wideband Bi-Sector™ Antenna

BSA33R-W3A

#### Electrical

Ports	8 × Mid Band Ports for 1695-2180 MHz		
Frequency Range	1695-1880 MHz	1850-1990 MHz	1920-2180 MHz
Gain	17.2 dBi	17.8 dBi	18.5 dBi
Azimuth Beamwidth (-3dB)	39°	36°	34°
Elevation Beamwidth (-3dB)	9.9°	9.0°	8.6°
Electrical Downtilt	0° to 10°	0° to 10°	0° to 10°
Elevation Sidelobes (1st Upper)	<-17 dB	<-17 dB	<-18 dB
Front-to-Back Ratio @180°	> 35 dB	> 35 dB	> 35 dB
Cross-Polar Discrimination at Peak	> 25 dB	> 23 dB	> 22 dB
Cross-Polar Port-to-Port Isolation	> 25 dB	> 25 dB	> 25 dB
Voltage Standing Wave Ratio (VSWR)	< 1.5:1	< 1.5:1	< 1.5:1
Passive Intermodulation (2x20W)	≤ -153 dBc	≤ -153 dBc	≤ -153 dBc
Input Power Continuous Wave (CW)	300 watts	300 watts	300 watts
Polarization	Dual Linear 45°	Dual Linear 45°	Dual Linear 45°
Input Impedance	50 ohms	50 ohms	50 ohms
Lightning Protection	DC Ground	DC Ground	DC Ground

BASTA Electrical Specifications	1695-1880 MHz	1850-1990 MHz	1920-2180 MHz
Frequency Range	1695-1880 MHz	1850-1990 MHz	1920-2180 MHz
Gain over all Tilts (dBi)	16.5	17.1	17.5
Gain over all Tilts Tolerance (dB)	0.4	0.3	0.3
Gain at Low-Tilt (dBi)	16.4	17.0	17.4
Gain at Mid-Tilt (dBi)	16.5	17.2	17.7
Gain at High-Tilt (dBi)	16.5	17.2	17.5
Azimuth Beamwidth Tolerance (°)	2.1	1.7	1.7
Elevation Beamwidth Tolerance (°)	0.5	0.2	0.3
Electrical Downtilt Deviation (°)	0.6	0.5	0.5
First Upper Sidelobes Suppression (dB)	14.7	14.1	13.9
Upper Sidelobe Suppression Peak to 20°(dB)	14.9	14.6	14.4
Front-to-Back Ratio over ±20° (dB)	27.8	28.1	27.3
Cross-polar Discrimination at 3 dB (dB)	14.7	12.6	11.8

\* Electrical specifications follow document "Recommendation on Base Station Antenna Standards" (BASTA) V11.1. All specifications are subject to change without notice.



# Antennas

## SPECIFICATIONS

### Wideband Bi-Sector™ Antenna

BSA33R-W3A

#### Mechanical

<b>Dimensions (LxWxD)</b>	37.4x24.0x6.2 in (949x610x158 mm)
<b>Survival Wind Speed</b>	> 150 mph (> 241 kph)
<b>Front Wind Load</b>	191 lbs (851 N) @ 100 mph (161 kph)
<b>Side Wind Load</b>	56 lbs (249 N) @ 100 mph (161 kph)
<b>Equivalent Flat Plate Area</b>	7.5 ft <sup>2</sup> (0.7 m <sup>2</sup> )
<b>Weight*</b>	45.2 lbs (20.5 kg)
<b>Connector</b>	8 x 4.3-10 female
<b>Mounting Pole</b>	2 to 5 in (5 to 12 cm)

*\* Weight excludes mounting*

#### Mechanical

Bottom View

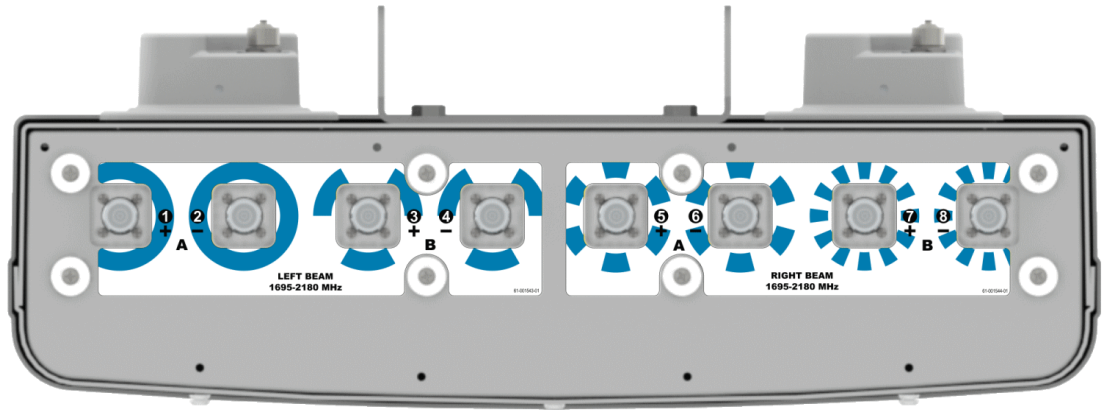

Connector Spacing

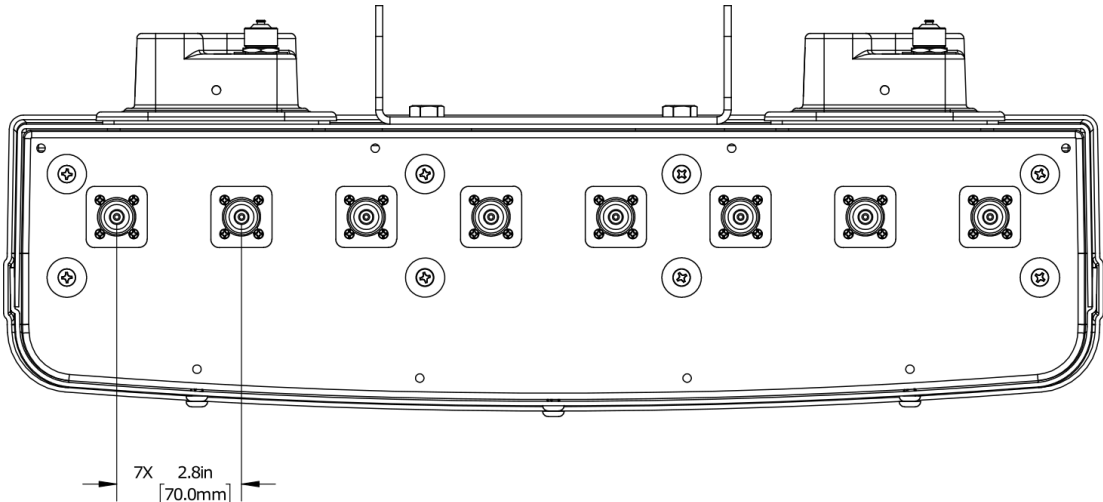



# Antennas

## SPECIFICATIONS

### Wideband Bi-Sector™ Antenna

BSA33R-W3A

#### Mechanical

#### Element and RET Configuration

### Top of antenna Viewed from rear

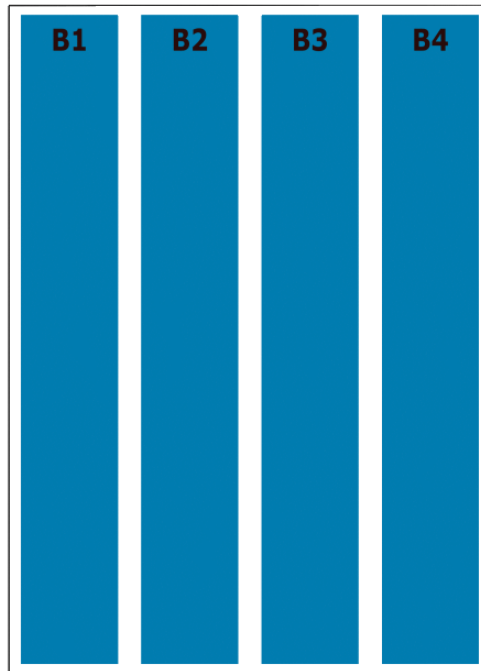

### RET placement as view from rear of antenna

Top of antenna



1695-2180  
**TILT  
B1 & B3**

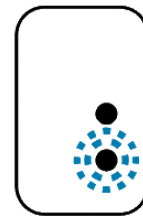

1695-2180  
**TILT  
B2 & B4**

Array	Ports	Freq (MHz)	Beam	Ports controlled by common RET
B1	1, 2	1695-2180	Left	1, 2, 3 & 4
B3	3, 4	1695-2180	Left	
B2	5, 6	1695-2180	Right	5, 6, 7 & 8
B4	7, 8	1695-2180	Right	



# Antennas

## SPECIFICATIONS

### Wideband Bi-Sector™ Antenna

BSA33R-W3A

#### Typical Antenna Patterns

For detailed information on additional antenna patterns, contact customer support at [support@cciproducts.com](mailto:support@cciproducts.com)

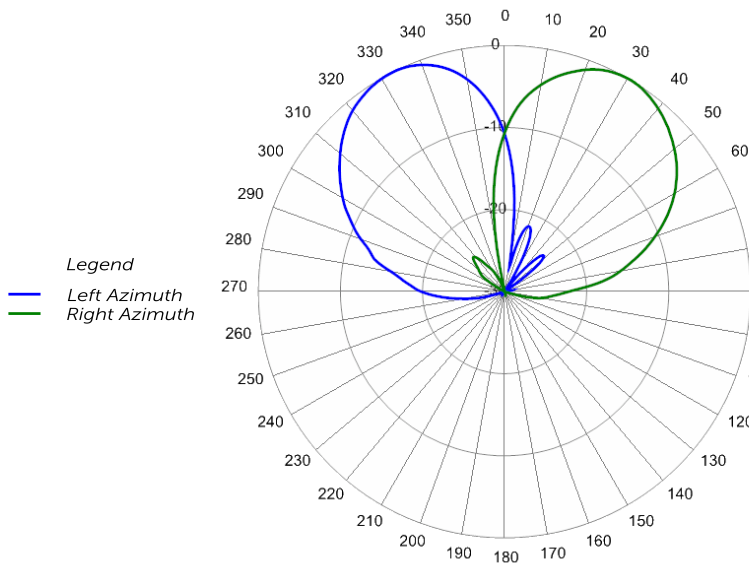

1900 MHz Azimuth

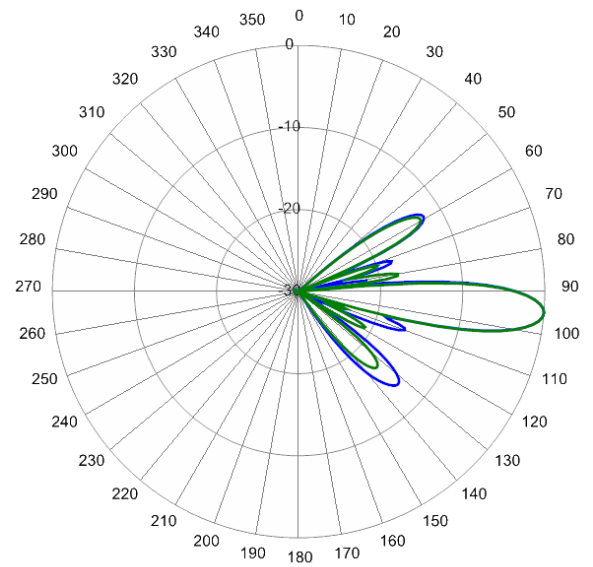

1900 MHz Elevation 5°

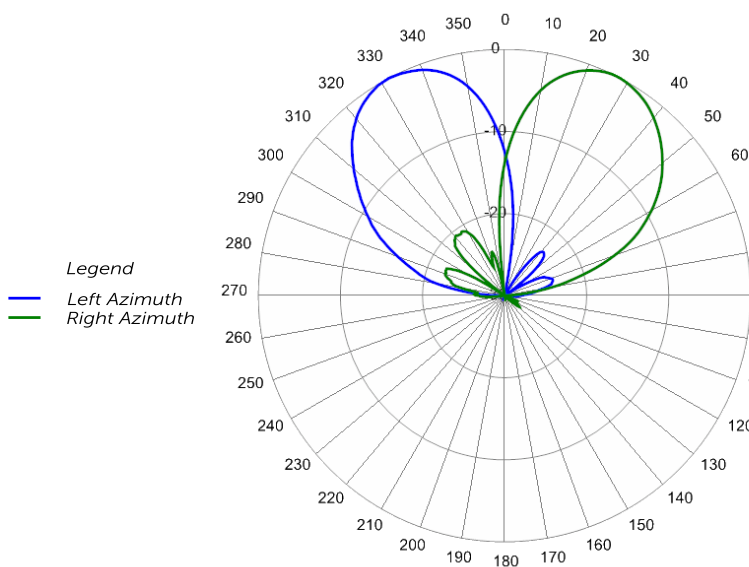

2120 MHz Azimuth

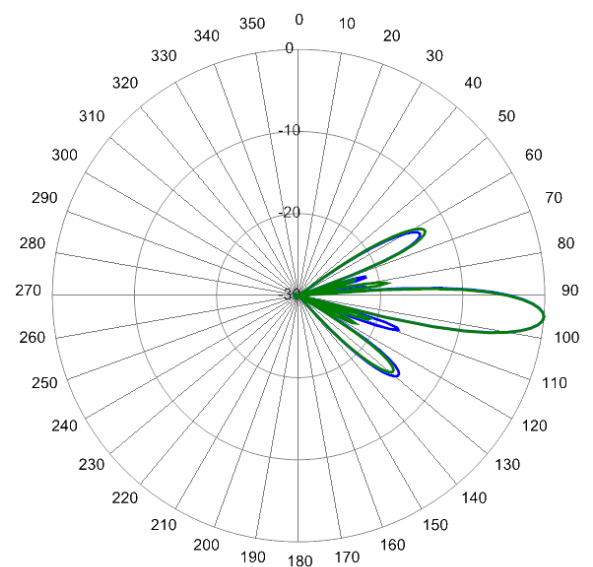

2120 MHz Elevation 5°



# Antennas

ORDERING

## Wideband Bi-Sector™ Antenna

BSA33R-W3A

### Parts & Accessories

<b>BSA33R-W3AA-K</b>	Three foot (0.9 m), eight port, Bi-Sector™ antenna with left and right azimuth beams covering 1695-2180 MHz. with 4.3-10 female connectors, 2 factory installed RET actuators and MBK-10 mounting bracket
<b>MBK-10</b>	Mounting bracket kit (top and bottom) with 0° to 10° mechanical tilt adjustment
<b>BSA-RET200</b>	Remote electrical tilt actuator
<b>CBK-AG-RRU-001</b>	Two RET antenna to RRU AISG cable kit
<b>CBK-RA-AG-RRU-001</b>	Two RET antenna to RRU AISG right angle cable kit



# Antennas

ACCESSORIES

## Mounting Bracket Kit

MBK-10

Mechanical

<b>Weight</b>	14.0 lbs (6.4 kg)
<b>Hinge Pitch</b>	23.6 in (600 mm)
<b>Mounting Pole Dimension</b>	2 to 5 in (5 to 12 cm)
<b>Fastener Size</b>	M12
<b>Installation Torque</b>	40 ft·lb (54 N·m)
<b>Mechanical Tilt Adjustment</b>	0° - 10°

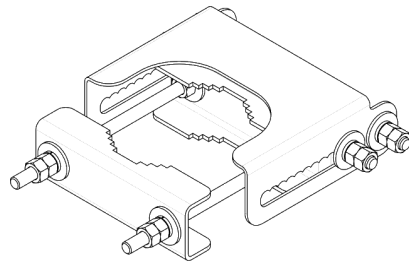

MBK-10 Top Adjustable Bracket

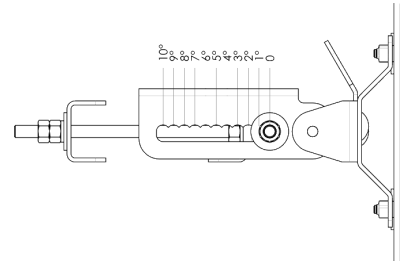

MBK-10 Top Adjustable Bracket Side View

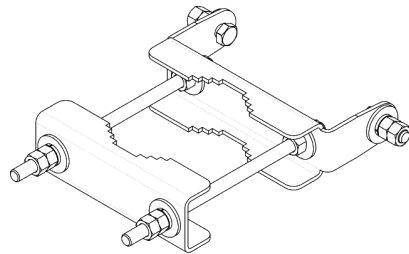

MBK-10 Bottom Fixed Bracket



# Antennas

ACCESSORIES

## Remote Electrical Tilt Actuator (RET)

BSA-RET200

### General Specifications

Part Number	BSA-RET200
Protocols	AISG 2.0
RET Type	Type 1
Adjustment Cycles	>10,000 cycles
Tilt Accuracy	±0.1°
Temperature Range	-40° C to 70° C

### Electrical

Data Interface Signal	DC
Input Voltage	10-30 Vdc
Current Consumption Tilt	120 mA at $V_{in}=24$
Current Consumption Idle	55 mA at $V_{in}=24$
Hardware Interface	AISG-RS 485 A/B
Input Connector	Male 1 × 8 pin Daisy Chain
Output Connector	Female 1 × 8 pin Daisy Chain

### Mechanical

Dimensions (LxWxD)	8.0x5.0x2.0 in. (213x135x51 mm)
Housing	ASA/ABS/Aluminum
Weight	1.7 lbs (0.75 kg)

ASA= Acrylic Styrene Acrylonitrile  
ABS=Acrylonitrile Butadiene Styrene

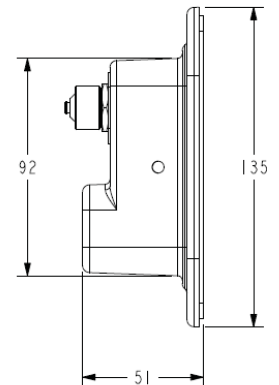
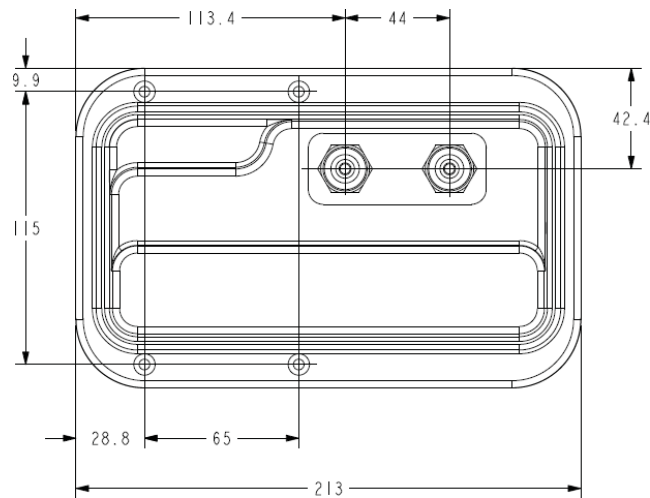





# Antennas

ACCESSORIES

## AISG Cable Kit

CBK-AG-RRU-001

### Electrical/Mechanical/Environmental Specifications

	RET to RET Cables	RRU to Antenna Cables
Individual Cable Part Number	AISGC-M-F-27	AISGC-M-F-10FT
Cable style	UL2464	
Protocol	AISG 1.1 and AISG 2.0	
Maximum voltage	300 V	
Rated current	5 A at 104° F (40° C)	
Temperature Range	-40° to 80° C	
Flammability	UL 1581 VW-1	
Ingress Protection	IEC 60529:2001, IP67	
Tightening torque	Hand tighten only $\approx$ 1.84 ft-lbs (2.5 N·m)	
Construction	Shielded (Tinned Copper Braid)	
Braid coverage	85%	
Jacket Material	Matte Polyurethane (Black)	
Conductors	1 twisted pair - 24 AWG 3 conductors - 19 AWG AWM style 2464	
Cable Diameter	0.307 in (7.8 mm)	
Minimum bend radius	3.9 in (100 mm)	
Connectors	2 x 8 pin IEC 60130-9 Straight male/straight female	
Length	27 in (686 mm)	120 in (3048 mm)
Weight	0.33 lbs (0.15 kg)	0.69 lbs (0.31 kg)
Cables per kit	1	2

### Mechanical Specifications

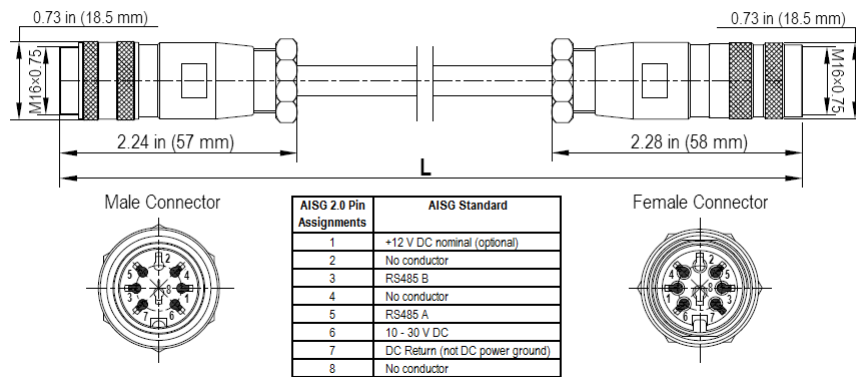

AISG-Male to AISG-Female Jumper Cable



# Antennas

ACCESSORIES

AISG Cable Kit

CBK-RA-AG-RRU-001

## Electrical/Mechanical/Environmental Specifications

	RET to RET Cables	RRU to Antenna Cables
Individual Cable Part Number	AISGC-MRA-FRA-27	AISGC-M-FRA-10FT
Cable style	UL2464	
Protocol	AISG 1.1 and AISG 2.0	
Maximum voltage	300 V	
Rated current	5 A at 104° F (40° C)	
Temperature Range	-40° to 80° C	
Flammability	UL 1581 VW-1	
Ingress Protection	IEC 60529:2001, IP67	
Tightening torque	Hand tighten only $\approx$ 1.84 ft-lbs (2.5 N·m)	
Construction	Shielded (Tinned Copper Braid)	
Braid coverage	85%	
Jacket Material	Matte Polyurethane (Black)	
Conductors	1 twisted pair - 24 AWG 3 conductors - 19 AWG AWM style 2464	
Cable Diameter	0.307 in (7.8 mm)	
Minimum bend radius	3.9 in (100 mm)	
Connectors	2 x 8 pin IEC 60130-9 Right angle male/right angle female	2 x 8 pin IEC 60130-9 Straight male/right angle female
Length	27 in (686 mm)	120 in (3048 mm)
Weight	0.20 lbs (0.09 kg)	0.77 lbs (0.35 kg)
Cables per kit	1	2

## Mechanical Specifications

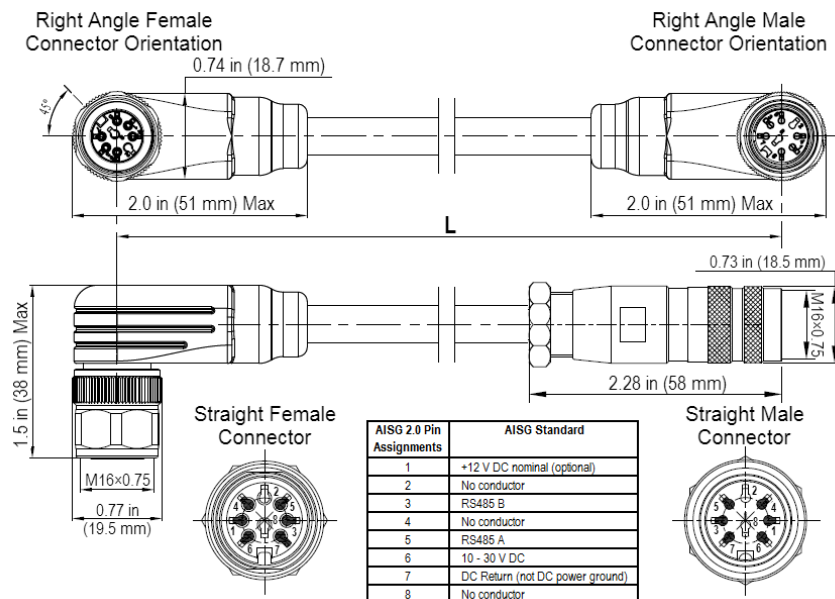

Right Angle to Right Angle and Right Angle to Straight Jumper Cable



# Antennas

## STANDARDS & CERTIFICATIONS

### Wideband Bi-Sector™ Antenna

BSA33R-W3A

#### Standards & Compliance

<b>Safety</b>	EN 60950-1, UL 60950-1
<b>Emission</b>	EN 55022
<b>Immunity</b>	EN 55024
<b>Environmental</b>	IEC 60068-2-1, IEC 60068-2-2, IEC 60068-2-5, IEC 60068-2-6, IEC-60068-2-11, IEC 60068-2-14, IEC 60068-2-18, IEC 60068-2-27, IEC 60068-2-29, IEC 60068-02-30, IEC 60068-2-52, IEC 60068-2-64, GR-63-CORE 4.3.1, EN 60529, IP 24

#### Certifications

Antenna Interface Standards Group (AISG), Federal Communication Commission (FCC) Part 15 Class B, CE, CSA US, ISO 9001

